

Fast CMOS 3.3V Octal D Flip-Flop
Product Features

- Compatible with LVT™ and FCT3 families of products
- 5V Tolerant inputs and outputs
- 2.0V - 3.6V V_{CC} supply operation
- Balanced sink and source output drives ($\pm 24\text{mA}$)
- Low ground bounce outputs
- Power Down High Impedance inputs and outputs
- Supports live insertion
- Hysteresis on all inputs
- ESD protection exceeds -
2000V, Human Body Mode
200V, Machine Mode
- Packages:
– 20-pin 173 mil -wide plastic TSSOP (L)
– 20-pin 150 mil- wide plastic QSOP (Q)
– 20-pin 300 mil -wide plastic SOIC (S)

Product Description

Pericom Semiconductor's PI74LCX series of logic circuits are produced using the Company's advanced 0.6 CMOS technology, achieving industry leading speed grades.

The PI74LCX374 is an 8-bit wide octal D-type flip flop designed with a buffered common clock and buffered 3-state outputs. When output enable ($\overline{\text{OE}}$) is LOW, the outputs are enabled. When $\overline{\text{OE}}$ is HIGH, the outputs are in the high impedance state. Input data meeting the setup and hold time requirements of the D inputs is transferred to the O outputs on the LOW-to-HIGH transition of the clock input.

The PI74LCX374 can be driven from either 3.3V or 5.0V devices allowing for the device to be used as a translator in a mixed 3.3V/5.0V system.

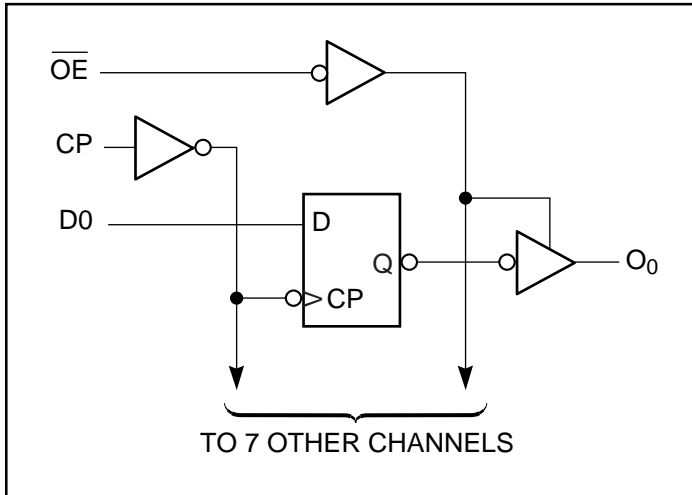
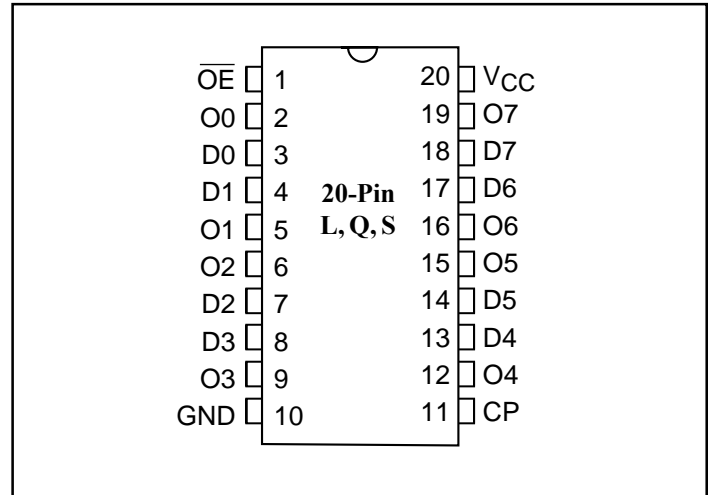
Logic Block Diagram

Product Pin Configuration

Truth Table⁽¹⁾

Inputs			Outputs
D _N	CP	$\overline{\text{OE}}$	O _N
H	↑	L	H
L	↑	L	L
X	L	L	O ₀
X	X	H	Z

Note:

1. H = High Voltage Level; X = Don't Care
L = Low Voltage Level; Z = High Impedance
↑ = LOW-to-HIGH Transition;
O₀ = Previous O₀ before High-to-Low of CP

Product Pin Description

Pin Name	Description
$\overline{\text{OE}}$	Output Enable Inputs (Active LOW)
CP	Clock Pulse, LOW-to-HIGH Transition
D0-D7	Data Inputs
O0-O7	3-State Outputs
GND	Ground
V _{CC}	Power

Maximum Ratings

(Above which the useful life may be impaired. For user guidelines, not tested.)

Storage Temperature	-65°C to +150°C
Ambient Temperature with Power Applied	-40°C to +85°C
Supply Voltage to Ground Potential (Inputs & V _{CC} Only)	-0.5V to +7.0V
Supply Voltage to Ground Potential (Outputs & D/O Only)	-0.5V to +7.0V
DC Input Voltage	-0.5V to +7.0V
DC Output Current	120mA
Power Dissipation	1.0W

Note:

Stresses greater than those listed under MAXIMUM RATINGS may cause permanent damage to the device. This is a stress rating only and functional operation of the device at these or any other conditions above those indicated in the operational sections of this specification is not implied. Exposure to absolute maximum rating conditions for extended periods may affect reliability.

Recommended Operating Conditions

Symbol	Parameters		Min.	Max.	Units
V _{CC}	Supply Voltage	Operating	2.0	3.6	V
		Data Retention	1.5	3.6	
V _I	Input Voltage		0	5.5	
V _O	Output Voltage	HIGH or LOW State	0	V _{CC}	
		3-State	0	5.5	
I _{OH} /I _{OL}	Output Current	V _{CC} = 3.0V - 3.6V	—	±24	
		V _{CC} = 2.7V	—	±12	
		V _{CC} = 2.3V - 2.7V	—	±8	
T _A	Free-Air Operating Temperature		-40	+85	°C
Δt/Δv	Input Edge Rate	V _{IN} = 0.8V - 2.0V, V _{CC} = 3.0V	0	10	ns/V

DC Electrical Characteristics (Over the Operating Range, $T_A = -40^\circ\text{C}$ to $+85^\circ\text{C}$, $V_{CC} = 2.7\text{V}$ to 3.6V)

Parameters	Description	Test Conditions ⁽¹⁾		Min.	Typ ⁽²⁾	Max.	Units
V_{IH}	Input HIGH Voltage	Guaranteed Logic HIGH Level		2.0	—	—	V
V_{IL}	Input LOW Voltage	Guaranteed Logic LOW Level		—	—	0.8	
V_{OH}	Output HIGH Voltage	$V_{CC} = 2.7\text{-}3.6$	$I_{OH} = -0.1\text{mA}$	$V_{CC}-0.2$	—	—	
		$V_{CC} = 2.7$	$I_{OH} = -12\text{mA}$	2.2	—	—	
		$V_{CC} = 3.0$	$I_{OH} = -18\text{mA}$	2.4	—	—	
			$I_{OH} = -24\text{mA}$	2.2	—	—	
V_{OL}	Output LOW Voltage	$V_{CC} = 2.7\text{-}3.6$	$I_{OL} = 0.1\text{mA}$	—	—	0.2	
		$V_{CC} = 2.7$	$I_{OL} = 12\text{mA}$	—	—	0.4	
		$V_{CC} = 3.0$	$I_{OL} = 16\text{mA}$	—	—	0.4	
			$I_{OL} = 24\text{mA}$	—	—	0.55	
V_{IK}	Clamp Diode Voltage	$V_{CC} = \text{Min.}, I_{IN} = -18\text{mA}$		—	-0.7	-1.2	
I_I	Input Leakage Current	$0 \leq V_I \leq 5.5\text{V}$	$V_{CC} = 2.7\text{-}3.6$	—	—	± 5	μA
I_{OZ}	3-State Output Leakage	$0 \leq V_O \leq 5.5\text{V}$ $V_I = V_{IH}$ or V_{IL}	$V_{CC} = 2.7\text{-}3.6$	—	—	± 5	
I_{OFF}	Power Down Disable	$V_{CC} = 0\text{V}, V_{IN}$ or $V_{OUT} \leq 5.5\text{V}$		—	—	10	
I_{CC}	Quiescent Power Supply Current	$V_{CC} = \text{Max.}$	$V_{IN} = \text{GND}$ or V_{CC}	—	0.1	10	
ΔI_{CC}	Quiescent Power Supply Current TTL Inputs HIGH	$V_{CC} = \text{Max.}$	$V_{IN} = V_{CC} - 0.6\text{V}^{(3)}$	—	—	500	

Notes:

1. For Max. or Min. conditions, use appropriate value specified under Electrical Characteristics for the applicable device type.
2. Typical values are at $V_{CC} = 3.3\text{V}$, $+25^\circ\text{C}$ ambient.
3. Per TTL driven input; all other inputs at V_{CC} or GND.

Capacitance

Parameters	Description	Test Conditions	Typ.	Units
C_{IN}	Input Capacitance	$V_{CC} = \text{Open}, V_I = 0\text{V}$ or V_{CC}	7	pF
C_{OUT}	Output Capacitance	$V_{CC} = 3.3\text{V}, V_I = 0\text{V}$ or V_{CC}	8	
C_{PD}	Power Dissipation Capacitance	$V_{CC} = 3.3\text{V}, V_I = 0\text{V}$ or $V_{CC}, F = 10\text{ MHz}$	25	

Switching Characteristics over Operating Range

Parameters	Description	Conditions	$V_{CC} = 3.3V \pm 0.3V$		$V_{CC} = 2.7V$		Units
			Min.	Max.	Min.	Max.	
f_{MAX}	Maximum Clock Frequency	$C_L = 50pF$ $R_L = 500\ ohms$	150	–	150	–	ns
t_{PLH} t_{PHL}	Propagation Delay CP to O _x		1.5	8.5	1.5	9.5	
t_{PZH} t_{PZL}	Output Enable time \overline{OE} to O _x		1.5	8.5	1.5	9.5	
t_{PHZ} t_{PLZ}	Output Disable Time \overline{OE} to O _x		1.5	7.5	1.5	8.5	
t_{SU}	Setup Time HIGH or LOW, D _x to CP		2.5	–	2.5	–	
t_H	Hold Time HIGH or LOW, D _x to CP		1.5	–	1.5	–	
t_W	Pulse Width		3.3	–	3.3	–	
$t_{sk(o)}$	Output Skew ⁽¹⁾		–	1.0	–	–	

Note:

1. Skew between any two outputs, of the same package, switching in the same direction.

Dynamic Switching Characteristics ($T_A = +25^\circ C$)

Parameters	Description	Test Conditions ⁽¹⁾	Typ.	Units
V_{OLP}	Dynamic Output LOW Peak Voltage	$V_{CC} = 3.3V, C_L = 50pF$ $V_{IH} = 3.3V, V_{IL} = 0V$	0.8	V
V_{OLV}	Dynamic Output LOW Valley Voltage			

Note:

1. Measured with n–1 outputs switching from High-to-Low or Low-to-High. The remaining output is measured in the LOW state.

20-Pin 173 Mil-Wide Plastic TSSOP (L) Package

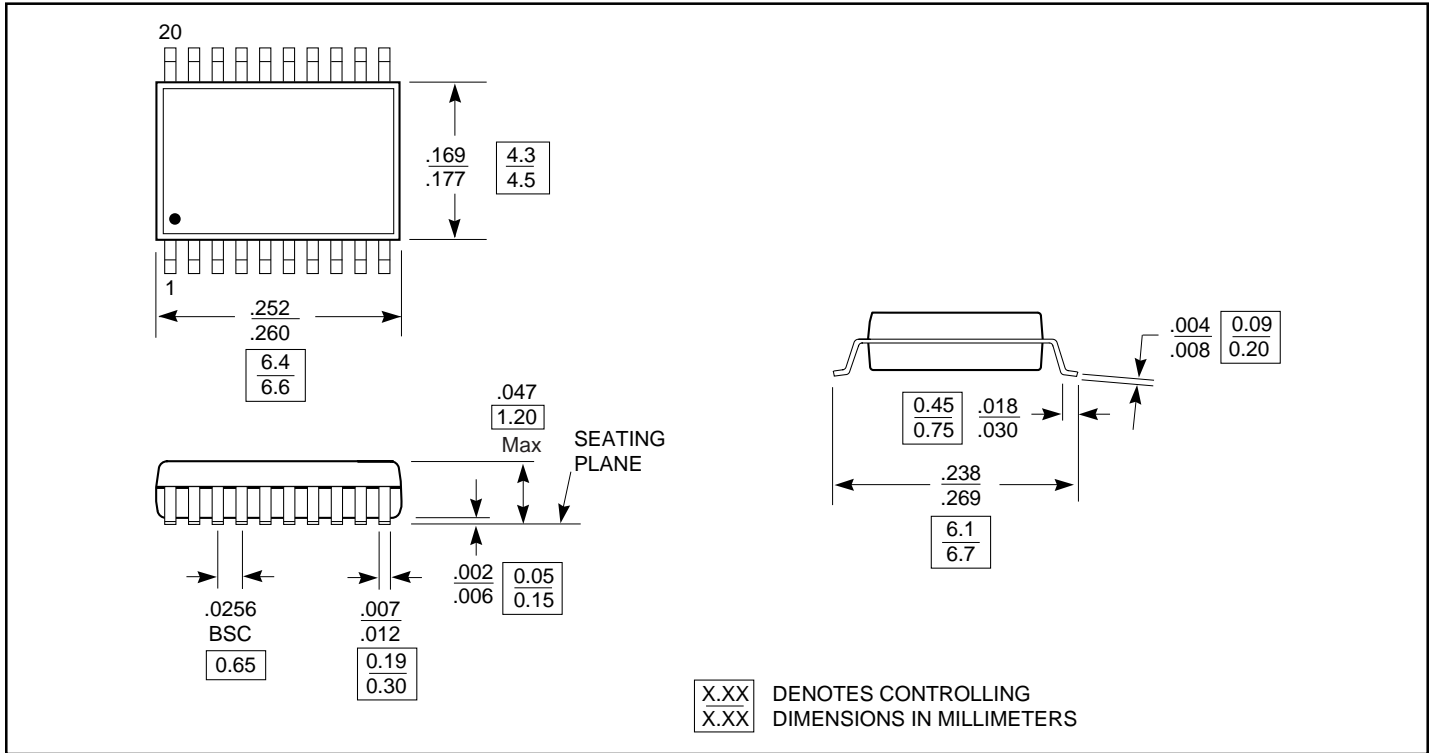

20-Pin 150 Mil-Wide Plastic QSOP (Q) Package

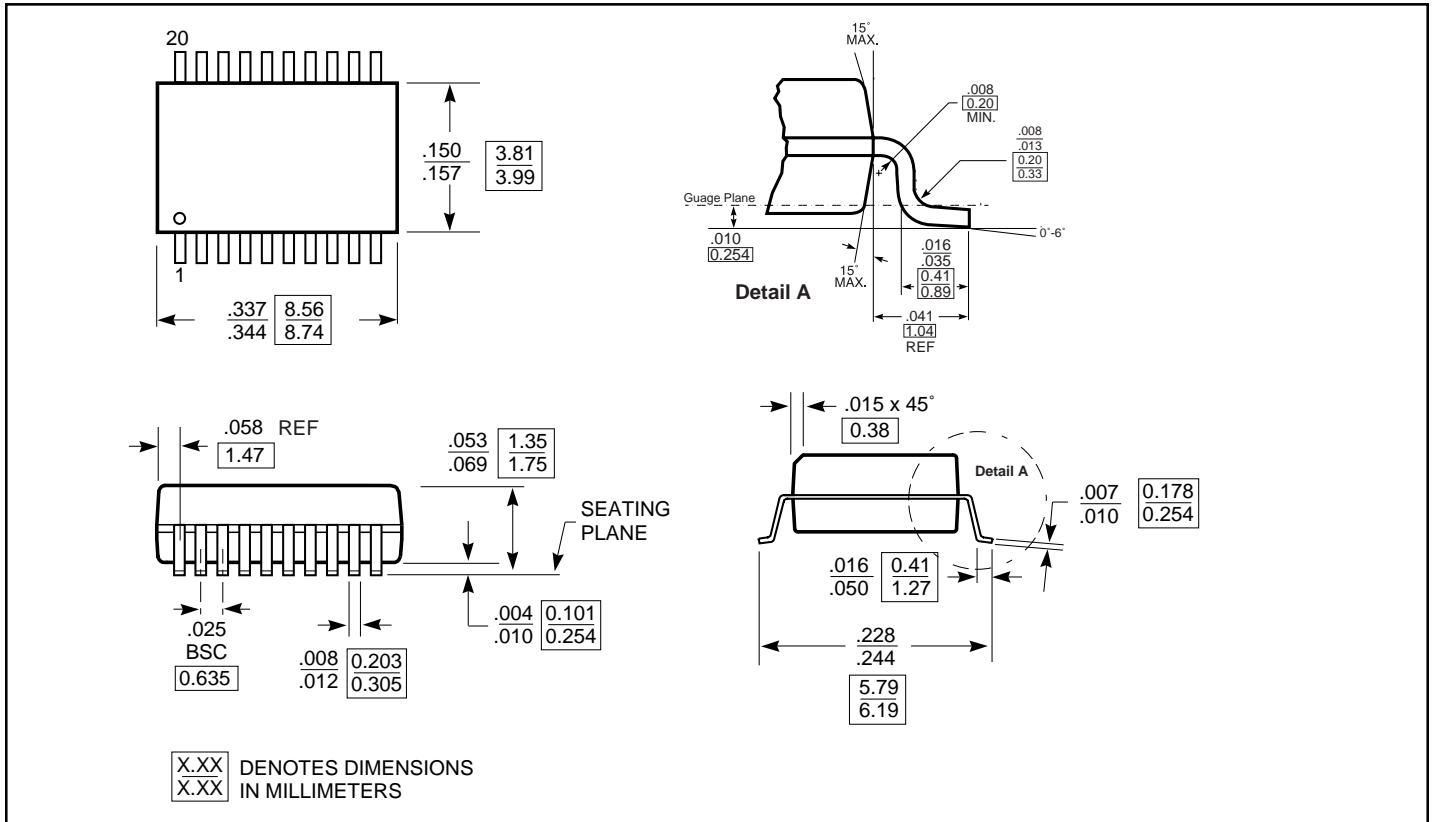

20-Pin 300 Mil-Wide Plastic SOIC (S) Package

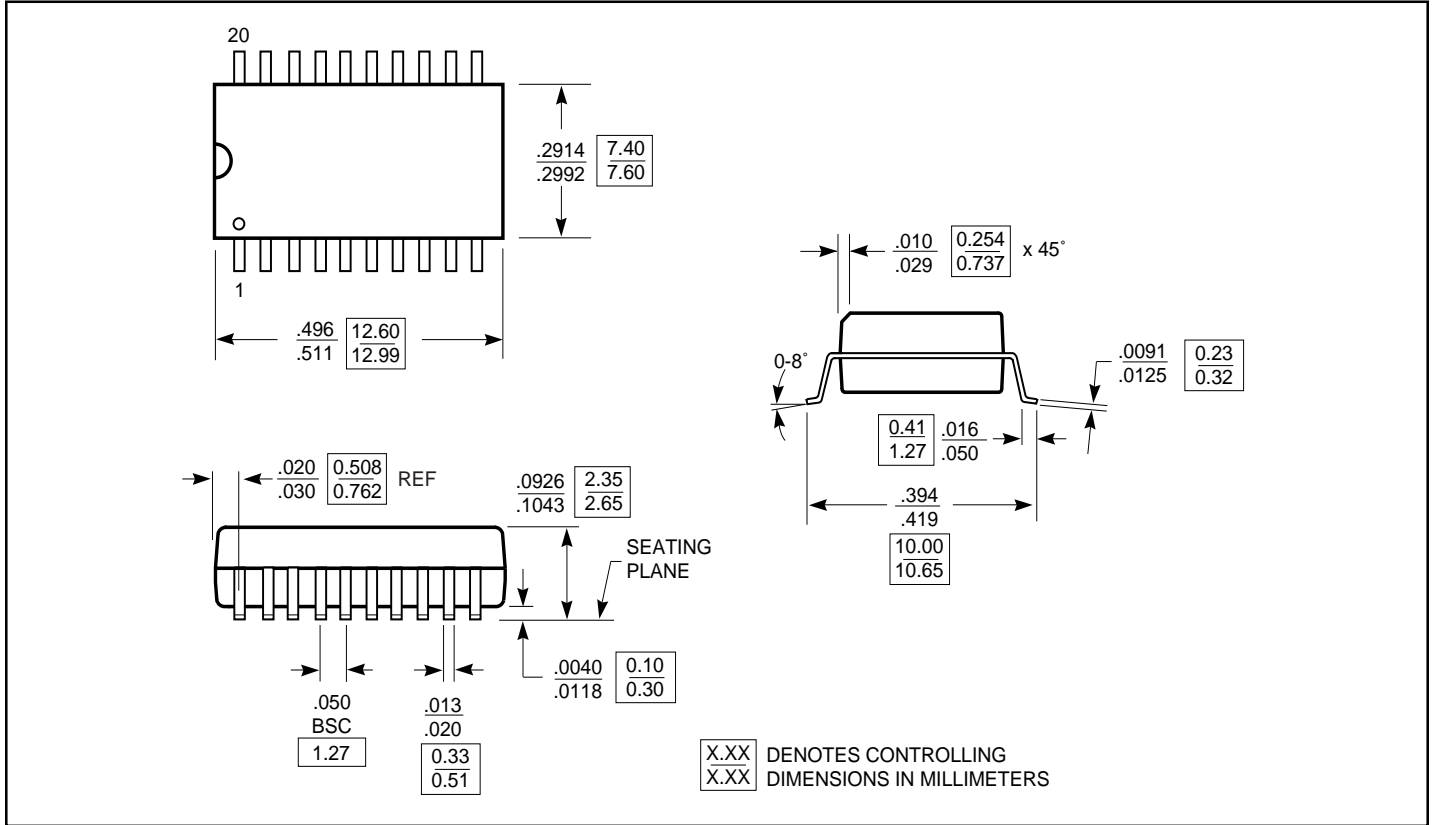

Ordering Information

Ordering Code	Description
PI74LCX374L	20-pin, 173-mil wide plastic TSSOP
PI74LCX374Q	20-pin, 150-mil wide plastic QSOP
PI74LCX374S	20-pin, 300-mil wide plastic SOIC

Note:

1. Thermal characteristics can be found on the web at <http://www.pericom.com/packaging>